

LAIRD

MANUFACTURING

"We are the Exception not the Compromise."

**VERTICAL
TRAILER-MOUNT**

**VR-2 SPEED
SERIES**

2 Speed Gearboxes | Narrow Body

[TABLE OF CONTENTS]

STANDARD EQUIPMENT

VR-675 CUFT VERTICAL MIXER TRAILER-MOUNT (TWIN-SCREW), (NARROW BODY)	2
<i>DIAGRAM</i>	2
<i>STANDARD EQUIPMENT DETAILS</i>	3
VR-750 CUFT VERTICAL MIXER TRAILER-MOUNT (TWIN-SCREW), (NARROW BODY)	4
<i>DIAGRAM</i>	4
<i>STANDARD EQUIPMENT DETAILS</i>	5
VR-800 CUFT VERTICAL MIXER TRAILER-MOUNT (TWIN-SCREW), (NARROW BODY)	6
<i>DIAGRAM</i>	6
<i>STANDARD EQUIPMENT DETAILS</i>	7
VR-900 CUFT VERTICAL MIXER TRAILER-MOUNT (TWIN-SCREW), (NARROW BODY)	8
<i>DIAGRAM</i>	8
<i>STANDARD EQUIPMENT DETAILS</i>	9
VR-1000 CUFT VERTICAL MIXER TRAILER-MOUNT (TWIN-SCREW), (NARROW BODY)	10
<i>DIAGRAM</i>	10
<i>STANDARD EQUIPMENT DETAILS</i>	11
OPTIONS	12
SPECIFICATION SHEET	14



VR-675 CUFT VERTICAL MIXER TRAILER-MOUNT (TWIN-SCREW, NARROW BODY)

[DIAGRAM]

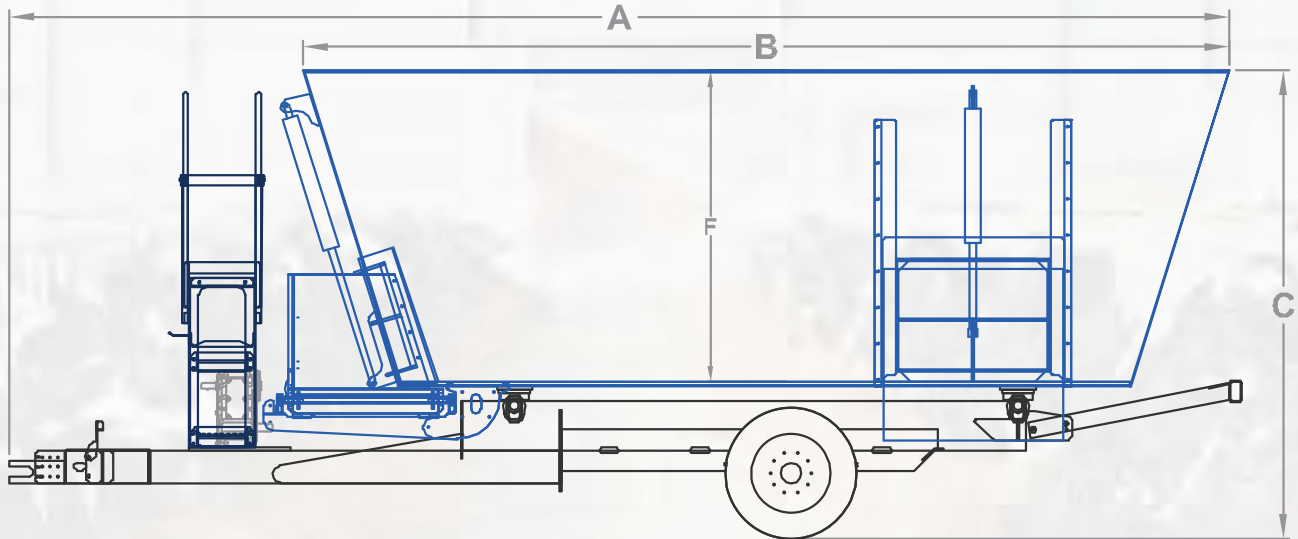

UNIT SPECIFICATIONS

	NUMBER OF SCREWS	2
	VOLUME (CU.FT.)	717
	MAX LOAD @ 25LBS/CU.FT.	17925
A	OVERALL LENGTH	294.00"
B	MIXING CHAMBER LENGTH	222.00"
C	OVERALL HEIGHT	110.00"
D	OVERALL WIDTH	124.50"
E	CHAMBER WIDTH	110.00"
F	CHAMBER DEPTH	72.00"
G	DISCHARGE CLEARANCE (STD. FLAT)	30.00"
	DISCHARGE CLEARANCE (DOGLEG)	42.00"
	PIVOT DISCHARGE @ MIN. CLEARANCE	34.00"
	DISCHARGE CLEARANCE (STD+CHUTE)	20.00"
H	SIDE DOOR CHUTE CLEARANCE	24"
	TRACTOR MIN. HORSE POWER	90
	NUMBER OF AXLES	1

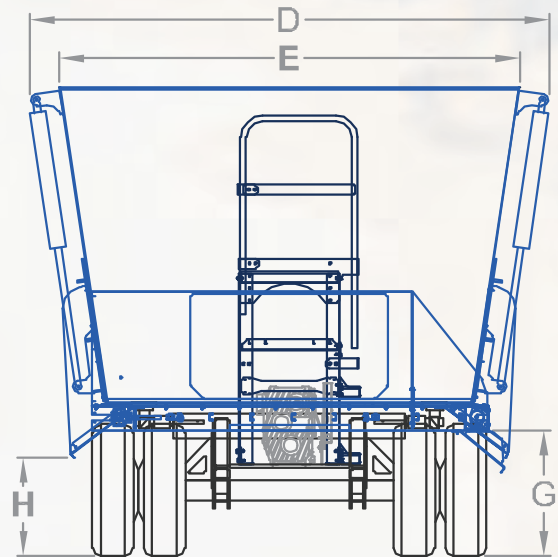

* ALL HEIGHTS BASED ON 75R17.5 TIRES

VR-675

VR-675 CUFT VERTICAL MIXER TRAILER-MOUNT (TWIN-SCREW, NARROW BODY)

[STANDARD EQUIPMENT]

1. 675 CUFT Mixing Chamber (6FT Side Wall)
2. ¾" Floor Thickness
3. Stainless Steel Liner on Floor (3mm)
4. Two Vertical Augers with Stainless Steel on the Perimeter Stainless Steel Cap (3mm) on the First Three Feet of the Leading Edge
5. Two Heavy Duty Planetary Gear Box Integrated with 90 Degree Bevel Gear
6. 125 HP Two Speed Gearbox (High Gear for Cleaning Out all the Remaining Feed and lower start up torque)
7. Hydraulically Operated Chain Discharge Conveyor in the Front that discharges to the Left Hand Side (Stainless Steel)
8. 4 Hydraulic Hoses
9. Ladder and Rear Bumper
10. PTO Shaft (540 RPM)
11. 4 X 235R/17.5 Tires on a Single Axle
12. Mechanical Jack
13. 4 X 10,000 lb Capacity Load Bars with 1% Accuracy
14. 18 X high Quality Tungsten Blades (2 Piece)
15. Painted White with Blue Trim
16. 2 Counter Knives



VR-750 CUFT VERTICAL MIXER TRAILER-MOUNT (TWIN-SCREW, NARROW BODY)

[DIAGRAM]

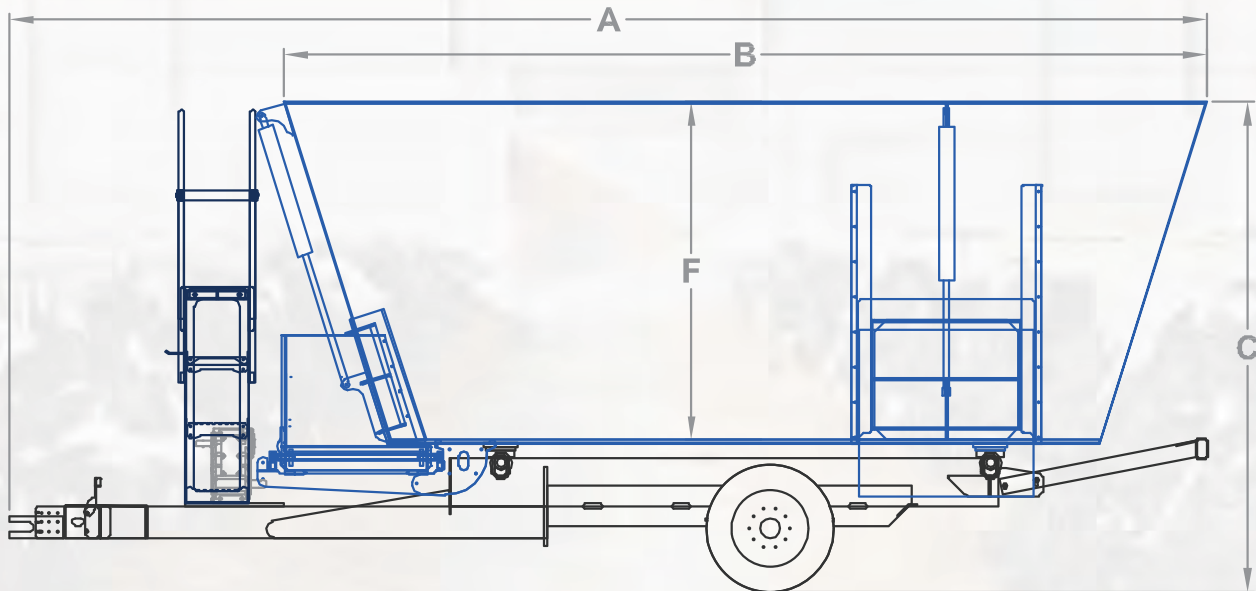

UNIT SPECIFICATIONS		
	NUMBER OF SCREWS	2
	VOLUME (CU.FT.)	790
	MAX LOAD @ 25LBS/CU.FT.	19750
A	OVERALL LENGTH	296.00"
B	MIXING CHAMBER LENGTH	226.00"
C	OVERALL HEIGHT	116.00"
D	OVERALL WIDTH	126.50"
E	CHAMBER WIDTH	112.00"
F	CHAMBER DEPTH	78.00"
G	DISCHARGE CLEARANCE (STD. FLAT)	30.00"
	DISCHARGE CLEARANCE (DOGLEG)	42.00"
	PIVOT DISCHARGE @ MIN. CLEARANCE	34.00"
	DISCHARGE CLEARANCE (STD+CHUTE)	20.00"
H	SIDE DOOR CHUTE CLEARANCE	24.00"
	TRACTOR MIN. HORSE POWER	90
	NUMBER OF AXLES	1

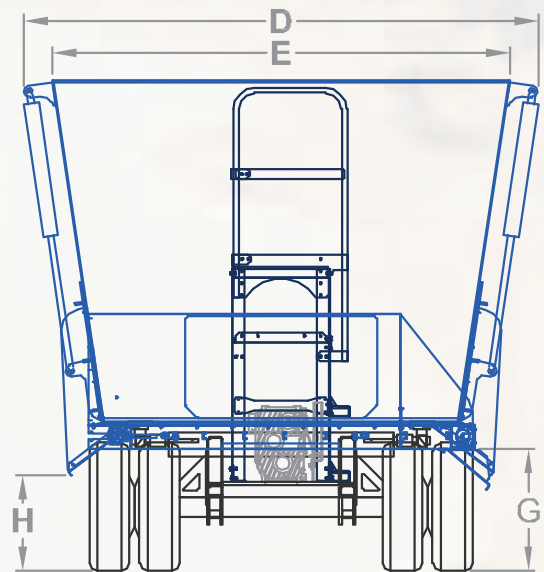

* ALL HEIGHTS BASED ON 75R17.5 TIRES

VR-750

VR-750 CUFT VERTICAL MIXER TRAILER-MOUNT (TWIN-SCREW, NARROW BODY)

[STANDARD EQUIPMENT]

1. 750 CUFT Mixing Chamber (6 ½ FT Side Wall)
2. ¾" Floor Thickness
3. Stainless Steel Liner on Floor (3mm)
4. Two Vertical Augers with Stainless Steel on the Perimeter Stainless Steel Cap (3mm) on the First Three Feet of the Leading Edge
5. Two Heavy Duty Planetary Gear Box Integrated with 90 Degree Bevel Gear
6. 125 HP Two Speed Gearbox (High Gear for Cleaning Out all the Remaining Feed)
7. Hydraulically Operated Chain Discharge Conveyor in the Front that discharges to the Left Hand Side 35" Wide (Stainless Steel)
8. 4 Hydraulic Hoses
9. Ladder and Rear Bumper
10. PTO Shaft (540 RPM)
11. 4 X 235R/17.5 Tires on a Single Axle
12. Mechanical Jack
13. 4 X 10,000 lb Capacity Load Bars with 1% Accuracy
14. 18 X high Quality Tungsten Blades (2 Piece)
15. Painted White with Blue Trim
16. 2 Counter Knives



VR-800 CUFT VERTICAL MIXER TRAILER-MOUNT (TWIN-SCREW, NARROW BODY)

[DIAGRAM]

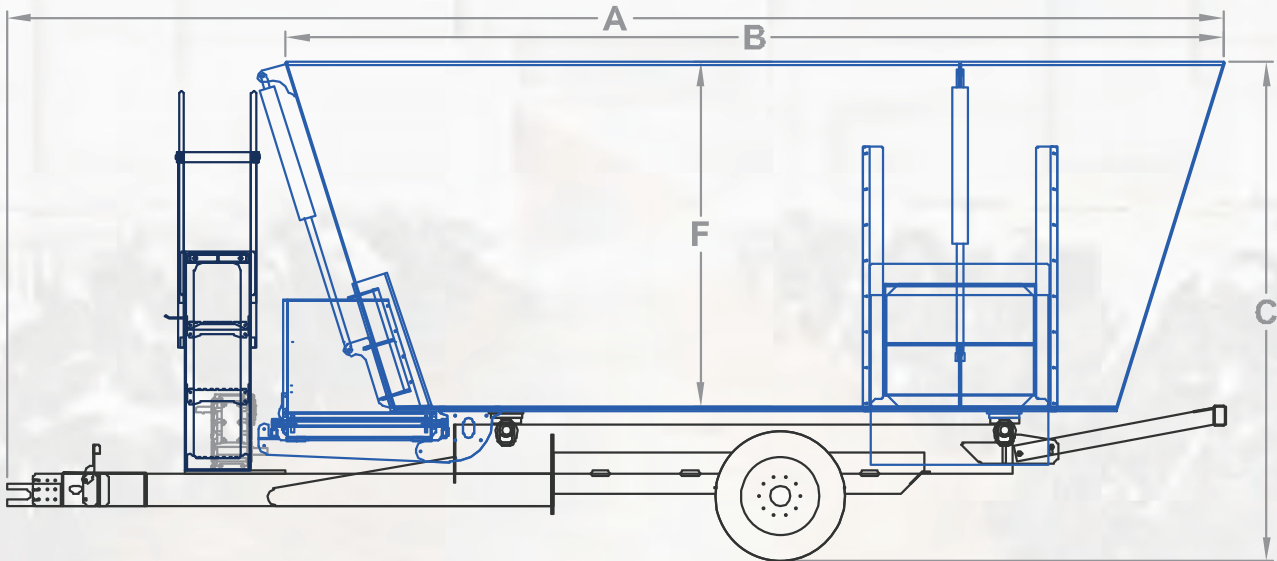

UNIT SPECIFICATIONS

	NUMBER OF SCREWS	2
	VOLUME (CU.FT.)	875
	MAX LOAD @ 25LBS/CU.FT.	21875
A	OVERALL LENGTH	298.00"
B	MIXING CHAMBER LENGTH	230.00"
C	OVERALL HEIGHT	122.00"
D	OVERALL WIDTH	128.50"
E	CHAMBER WIDTH	114.00"
F	CHAMBER DEPTH	84.00"
G	DISCHARGE CLEARANCE (STD. FLAT)	30.00"
	DISCHARGE CLEARANCE (DOGLEG)	42.00"
	PIVOT DISCHARGE @ MIN. CLEARANCE	34.00"
	DISCHARGE CLEARANCE (STD+CHUTE)	20.00"
H	SIDE DOOR CHUTE CLEARANCE	24"
	TRACTOR MIN. HORSE POWER	110
	NUMBER OF AXLES	1

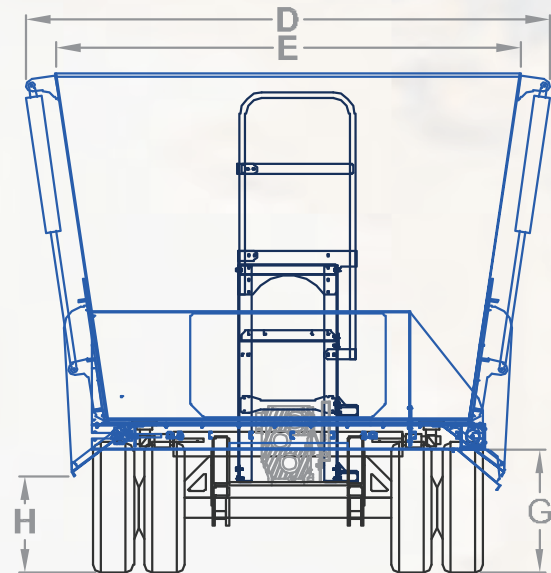

* ALL HEIGHTS BASED ON 75R17.5 TIRES

VR-800

VR-800 CUFT VERTICAL MIXER TRAILER-MOUNT (TWIN-SCREW, NARROW BODY)

[STANDARD EQUIPMENT]

1. 800 CUFT Mixing Chamber (7 FT Side Wall)
2. ¾" Floor Thickness
3. Stainless Steel Liner on Floor (3mm)
4. Two Vertical Augers with Stainless Steel on the Perimeter Stainless Steel Cap (3mm) on the First Three Feet of the Leading Edge
5. Two Heavy Duty Planetary Gear Box Integrated with 90 Degree Bevel Gear
6. 125 HP Two Speed Gearbox (High Gear for Cleaning Out all the Remaining Feed)
7. Hydraulically Operated Chain Discharge Conveyor in the Front that discharges to the Left Hand Side 35" Wide (Stainless Steel)
8. 4 Hydraulic Hoses
9. Ladder and Rear Bumper
10. PTO Shaft (540 RPM)
11. 4 X 235R/17.5 Tires on a Single Axle
12. Mechanical Jack
13. 4 X 10,000 lb Capacity Load Bars with 1% Accuracy
14. 18 X high Quality Tungsten Blades (2 Piece)
15. Painted White with Blue Trim
16. 2 Counter Knives



VR-900 CUFT VERTICAL MIXER TRAILER-MOUNT (TWIN-SCREW, NARROW BODY)

[DIAGRAM]

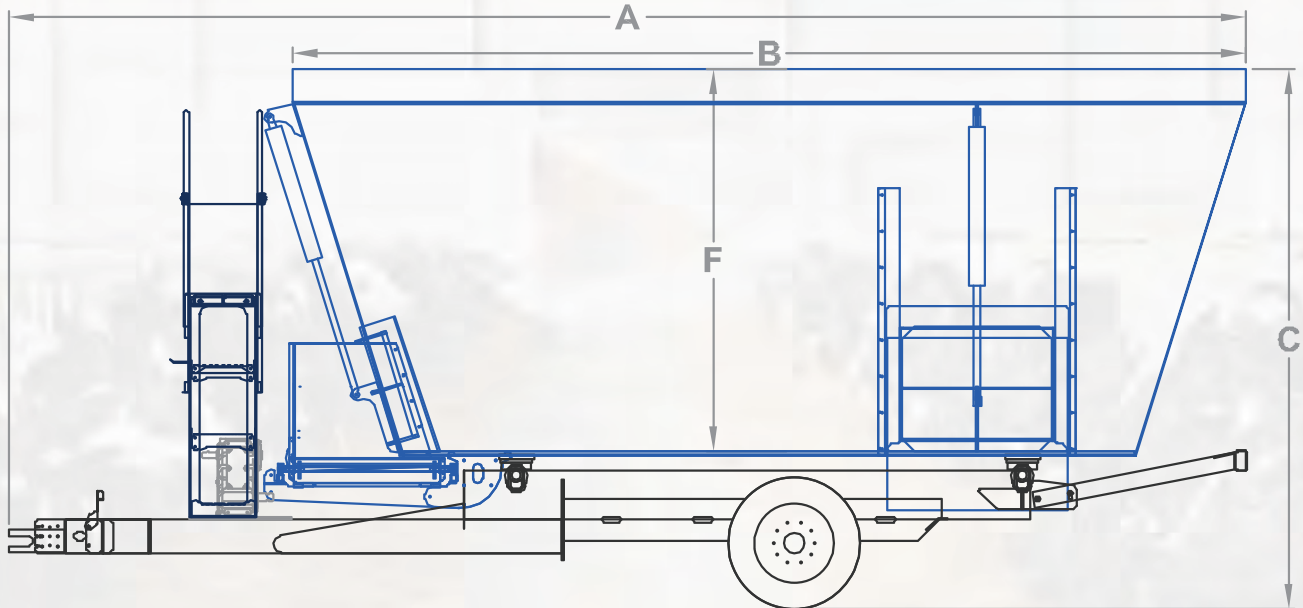

UNIT SPECIFICATIONS

	NUMBER OF SCREWS	2
	VOLUME (CU.FT.)	893
	MAX LOAD @ 25LBS/CU.FT.	22325
A	OVERALL LENGTH	298.00"
B	MIXING CHAMBER LENGTH	230.00"
C	OVERALL HEIGHT	130.00"
D	OVERALL WIDTH	128.50"
E	CHAMBER WIDTH	114.00"
F	CHAMBER DEPTH	92.00"
G	DISCHARGE CLEARANCE (STD. FLAT)	30.00"
	DISCHARGE CLEARANCE (DOGLEG)	42.00"
	PIVOT DISCHARGE @ MIN. CLEARANCE	34.00"
	DISCHARGE CLEARANCE (STD+CHUTE)	20.00"
H	SIDE DOOR CHUTE CLEARANCE	24"
	TRACTOR MIN. HORSE POWER	110
	NUMBER OF AXLES	1

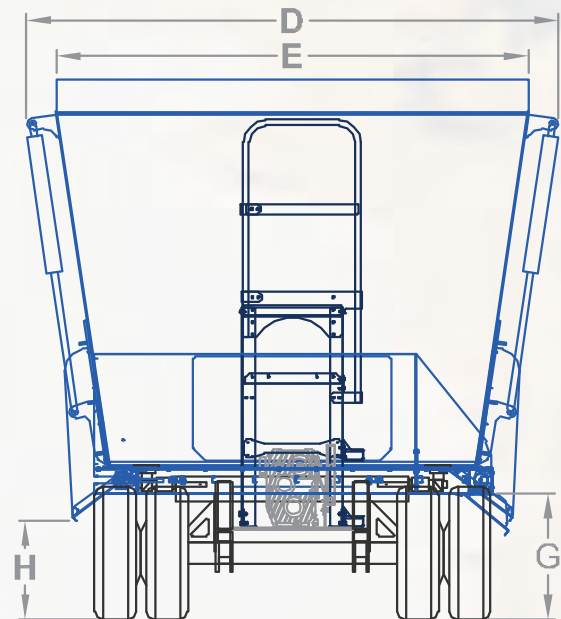

* ALL HEIGHTS BASED ON 75R17.5 TIRES

VR-900

VR-900 CUFT VERTICAL MIXER TRAILER-MOUNT (TWIN-SCREW, NARROW BODY)

[STANDARD EQUIPMENT]

1. 800 CUFT Mixing Chamber (7 FT Side Wall plus 8" belt extension)
2. ¾" Floor Thickness
3. Stainless Steel Liner on Floor (3mm)
4. Two Vertical Augers with Stainless Steel on the Perimeter Stainless Steel Cap (3mm) on the First Three Feet of the Leading Edge
5. Two Heavy Duty Planetary Gear Box Integrated with 90 Degree Bevel Gear
6. 125 HP Two Speed Gearbox (High Gear for Cleaning Out all the Remaining Feed)
7. Hydraulically Operated Chain Discharge Conveyor in the Front that discharges to the Left Hand Side 35" Wide (Stainless Steel)
8. 4 Hydraulic Hoses
9. Ladder and Rear Bumper
10. PTO Shaft (540 RPM)
11. 4 X 235R/17.5 Tires on a Single Axle
12. Mechanical Jack
13. 4 X 10,000 lb Capacity Load Bars with 1% Accuracy
14. 18 X high Quality Tungsten Blades (2 Piece)
15. Painted White with Blue Trim
16. 2 Counter Knives



VR-1000 CUFT VERTICAL MIXER TRAILER-MOUNT (TWIN-SCREW, NARROW BODY)

[DIAGRAM]

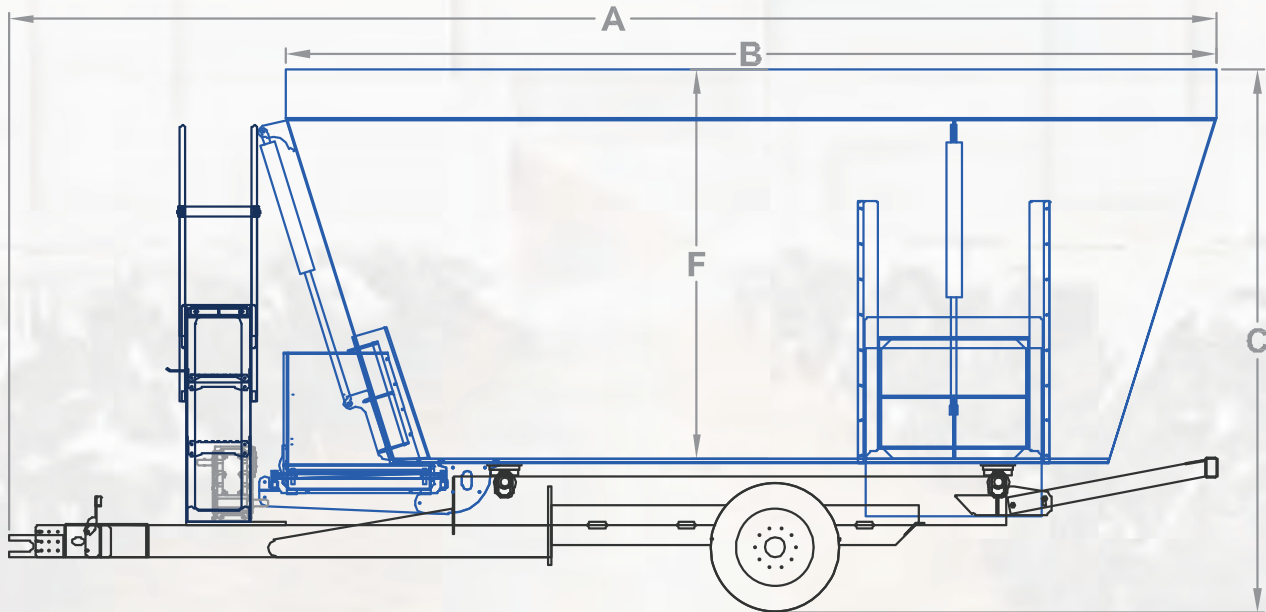

UNIT SPECIFICATIONS

	NUMBER OF SCREWS	2
	VOLUME (CU.FT.)	947
	MAX LOAD @ 25LBS/CU.FT.	23675
A	OVERALL LENGTH	298.00"
B	MIXING CHAMBER LENGTH	230.00"
C	OVERALL HEIGHT	136.00"
D	OVERALL WIDTH	128.5"
E	CHAMBER WIDTH	114.00"
F	CHAMBER DEPTH	96.00"
G	DISCHARGE CLEARANCE (STD. FLAT)	31.5"
	DISCHARGE CLEARANCE (DOGLEG)	43.5"
	PIVOT DISCHARGE @ MIN. CLEARANCE	35.5"
	DISCHARGE CLEARANCE (STD+CHUTE)	21.5"
H	SIDE DOOR CHUTE CLEARANCE	25.5"
	TRACTOR MIN. HORSE POWER	120
	NUMBER OF AXLES	1

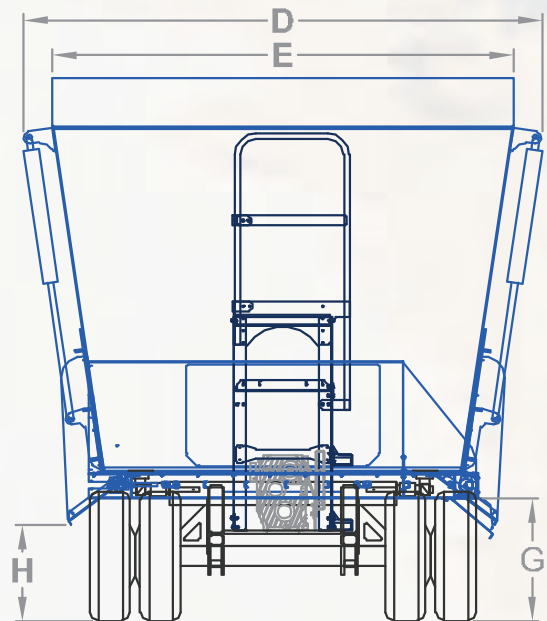

* ALL HEIGHTS BASED ON 75R17.5 TIRES

VR-1000

VR-1000 CUFT VERTICAL MIXER TRAILER-MOUNT (TWIN-SCREW, NARROW BODY)

[STANDARD EQUIPMENT]

1. 800 CUFT Mixing Chamber (7 FT Side Wall plus 8" belt extension)
2. ¾" Floor Thickness
3. Stainless Steel Liner on Floor (3mm)
4. Two Vertical Augers with Stainless Steel on the Perimeter Stainless Steel Cap (3mm) on the First Three Feet of the Leading Edge
5. Two Heavy Duty Planetary Gear Box Integrated with 90 Degree Bevel Gear
6. 125 HP Two Speed Gearbox (High Gear for Cleaning Out all the Remaining Feed)
7. Hydraulically Operated Chain Discharge Conveyor in the Front that discharges to the Left Hand Side 35" Wide (Stainless Steel)
8. 4 Hydraulic Hoses
9. Ladder and Rear Bumper
10. PTO Shaft (540 RPM)
11. 4 X 235R/17.5 Tires on a Single Axle
12. Mechanical Jack
13. 4 X 10,000 lb Capacity Load Bars with 1% Accuracy
14. 18 X high Quality Tungsten Blades (2 Piece)
15. Painted White with Blue Trim
16. 2 Counter Knives



VR-1000

VERTICAL TRAILER-MOUNT MIXER

with 2 Speed Gearboxes
Narrow Body

VR-2-Speed Series

[OPTIONS: ALL TWO-SPEED TRAILERS]

1. Floor Thickness Upgrades:- Twin Auger - 3/4" floor to 1" floor
2. Stainless Steel Floor Upgrade: Stainless Steel Floor (3mm to 5mm):
Twin Screws (Narrow Body)
3. 8" Belting Extension: TWIN SCREW
4. 8" Cut-Out Option (Per Side)
5. 12" Steel Extension (1/4" Material)
20" Steel Extension (1/4" Material)
6. Rear Door for Premix (50" Wide x 32.5" High)
Extra Large Rear Door (60" Wide x 32.5" High)
7. Side Door and Slide Chute (Per Door)
8. Extra Kicker (Per Auger) (Recommended when using side doors)
9. Scale Installation
10. Power Cord
11. 2-Speed Shifting Cable
12. Electric Shifting Option on 2-Speed Gear Box
13. Stainless Steel Sides(2mm): Stainless Steel Sides(2.5mm): Stainless Steel Sides (3.0mm):
 VR-555 VR-555 VR-555
 VR-475T VR-475T VR-475T
 VR-555T VR-555T VR-555T
 VR-675 VR-675 VR-675
 VR-750 VR-750 VR-750
 VR-800 VR-800 VR-800
 VR-900 VR-900 VR-900
 VR-1000 (N) VR-1000 (N) VR-1000 (N)
14. Rear Light and Feeding Light
15. Light Package built into Rear Bumper (LED)
16. Non-Standard Paint Color, Custom-made decals
17. Door Indicator Gauge: (For One Door)
Additional Doors (each)
18. Telescopic Discharge (Hydraulic)
19. Tilting Discharge (Hydraulic) (36")
20. Magnets on Slide Chute



OPTIONS

VERTICAL TRAILER-MOUNT MIXER

with 2 Speed Gearboxes
Narrow Body **VR-2-Speed Series**

[OPTIONS CONT: ALL TWO-SPEED TRAILERS]

21. Battery (with Enclosure)
22. Viewing Platform
23. for Right Hand Side
24. Tandem Axles and Spring Suspension Discharge Incline Option
25. Discharge Extension Option (6 inch)
Discharge Extension Option (12 inch)
Discharge Extension Option(18 inch)
26. Extra Discharge Motor
27. Heavy Duty Single Point Suspension (Up-Grade)
28. Upgrade from Standard Tandem Axles to Single Point Suspension
29. Tri-Dem Axles (3 Axles) 2 Steering/One Fixed with Brakes
30. 6" of Stainless Steel Lining on each Auger(3mm)
6" of Stainless Steel Lining on each Auger(5mm)
31. Complete Stainless Steel (3mm) Lining on each Auger
Complete Stainless Steel (5mm) Lining on each Auger
32. Feedlot style folding spout
33. Dogleg Discharge Conveyor (79"+30")
Dogleg Discharge Conveyor (90"+30")
34. Constant Velocity (CV) PTO
35. UHMW Plastic Rails on Discharge with overhead support brackets (Requires Option 18)
36. C2082H Roller Chain (Up-Charge)
37. Up-Grade from 17.5 Tires to 22.5 Tires (Per Axle)
38. Swing gate for dual sided discharge conveyor
39. 3 position drop chute (steel+ rubber)
40. Stationary drop chute (no magnets)
41. Discharge Overhead support brackets



VERTICAL TRAILER-MOUNT MIXER

with 2 Speed Gearboxes **VR-2-Speed Series**
Narrow Body

[SPECIFICATION SHEET]

Customer Name: _____ **Company Name:** _____

Date: _____ **Model:** _____

Options for all Two-Speed Trailers		Yes	Price
BASE PRICE			
1	Upgrade Floor Thickness: Twin Auger: _____ 3/4" - 1"		
2	Stainless Steel Floor Upgrade from 3mm to 5mm		
3	8" Belting Extension _____ Single Screw _____ Twin Screw		
4	8" Cut-out Option (per side) _____ LHS _____ RHS _____ Both Sides		
5	Steel Extension (1/4" material) _____ 12" _____ 20" _____ Other		
6	Rear Door for Premix _____ Standard (50" W x 32.5" H) _____ Ex Large (60"W x 32.5"H)		
7	Side-Door and Slide-Chute (Per Door) Front: _____ LHS _____ RHS Rear: _____ LHS _____ RHS		
8	Extra Kicker (Per Auger) _____ Front _____ Rear		
9	Scale Installation		
10	Power Cord		
11	Two-speed Shifting Cable		
12	Electric Shifting Option on two-speed Gear Box		
13	Stainless Steel Sides _____ 2mm _____ 2.5mm _____ 3.0 mm		
14	Rear Light and Feeding Light		
15	Light package built-into rear bumper (LED)		
16	Non-Standard Paint Color _____ Custom Decal _____		
17	Door Indicator Gauge: _____ One Door _____ Additional Doors		
18	Telescopic Discharge (Hydraulic)		
19	Tilting Discharge _____ Hydraulic 36" _____ Hydraulic 42"		
20	Magnets on Slide Chute		
21	Battery with Enclosure		
22	Viewing Platform		
23	Discharge Incline Option		
24	Discharge Extension Option: _____ 6" _____ 12" _____ 18"		
25	Extra Discharge Motor for Right-hand side		
26	Tandem Axles and Spring Suspension		
27	Heavy-duty Single-Point Suspension (Up-Grade)		
28	Upgrade from Standard Tandem Axles to Single-Point Suspension		
29	Tri-Dem Axles (3) Axles Two Steering – One fixed with brakes		
30	6" of Stainless Steel Lining on each Auger _____ 3mm _____ 5mm		
31	Complete Stainless Steel Lining on each Auger _____ 3mm _____ 5mm		
32	Feedlot-Style Folding Spout		
33	Dogleg Discharge Conveyor _____ (79" + 30") _____ (90" + 30")		
34	Constant Velocity (CV) PTO		
35	UHMW Plastic Rails on Discharge w/overhead support brackets-Requires Option 18		
36	C2082H Roller Chain (Up-Charge)		
37	Up-Grade from 17.5" tires to 22.5" Tires (Per Axle)		
38	Swing Gate for dual-sided discharge conveyor		
39	3-position drop chute (Steel + rubber)		
40	Stationary drop chute (No magnets)		
41	Discharge overhead support brackets		
Scale System: Indicator _____ Remote _____ 2nd Remote _____ Other _____			
Hitch Pin: Single Lip _____ Double Lip _____ Pin Size _____			
PTO Specs – 1 3/8" _____ 1 3/4" _____ 540 _____ 1000			
Blade Option: 2-piece _____ Busatis _____ Feedlot Backing Plate _____			
Credit For: _____ No Discharge Conveyor _____ No Front Door _____ No St Steel Liner on Floor			()

Every Laird Product Is *Custom Built* For You.



531 S. Hwy. 59 | Merced, CA 95341
P: (209) 722-4145 | F: (209) 349-8934
sales@lairdmfg.com | www.lairdmfg.com

